

• ECR 90-25 TYPE



Protection rate: **IP40**
 Insulation class: **B (130°C)**
 Reference cycle: **5 minutes**
 Standard stroke (s): **25 mm**
 Temperature rise "ΔV₃₁": **70°C**
 Working temperature: **-10 to 45°C**
 Work: **Push / Pull**

Release spring NOT
 incorporated in standard
 product.

(ED) Duty-cycle ED(%)	100	40	25	15	5
(P20) Power at 20°C (W)	55	125	190	300	900
(Fm) Solenoid force (N) 1)	70	111	146	178	305
Max time under voltage(s)	Inf	120	75	45	15
Opening time (ms) 2)	651	488	417	332	307
Release time (ms) 3)	399	301	259	208	193
Plunger weight (Kg)	0.900				
Solenoid weight (Kg)	8.5				

1) Fm Solenoid force is given according to VDE0580 without deducting the spring force or the plunger weight if vertical mounting.

2) Time is given on these conditions: Coil supplied under nominal voltage ; Stabilized in it's working temperature ; Load 70% of the solenoid force ; Horizontal assembly ; Standard stroke initial position; 20°C ambient temperature.

3) Time is given on these conditions: without load on shaft ; Horizontal assembly ; Standard stroke initial position.

Duty-cycle ED%	Standard voltages								Under demand				
	VDC						VAC		VDC		VAC		
	6	12	24	48	100	125	205	110	230	Min	Max	Min	Max
100	x	o	o	o	o	o	o	x	x	12	250	x	x
40	x	x	o	o	o	o	o	x	x	24	250	x	x
25	x	x	o	o	o	o	o	x	x	24	250	x	x
15	x	x	o	o	o	o	o	x	x	24	250	x	x
5	x	x	o	o	o	o	o	x	x	24	250	x	x

Layout: o = Available ; x = Unavailable

- Voltage under demand:
 They can be manufactured at voltages between the maximum and minimum voltage values shown in the chart.

- To feed in alternating current, there has to be an external rectification of the signal.

- The duty cycles described in the chart are standard, they can be manufactured in any intermediate value.

- If any customization from the original is needed, please ask us.

- Earthing is recommended if the metallic parts are accessible.

Ordering code: ECR90-25 --V ED---%
 Voltage: 24Vdc; Duty cycle: ED100%; ECR90-25 24Vdc ED100%
 Voltage: 48Vdc; Duty cycle: ED15%; ECR90-25 48Vdc ED15%

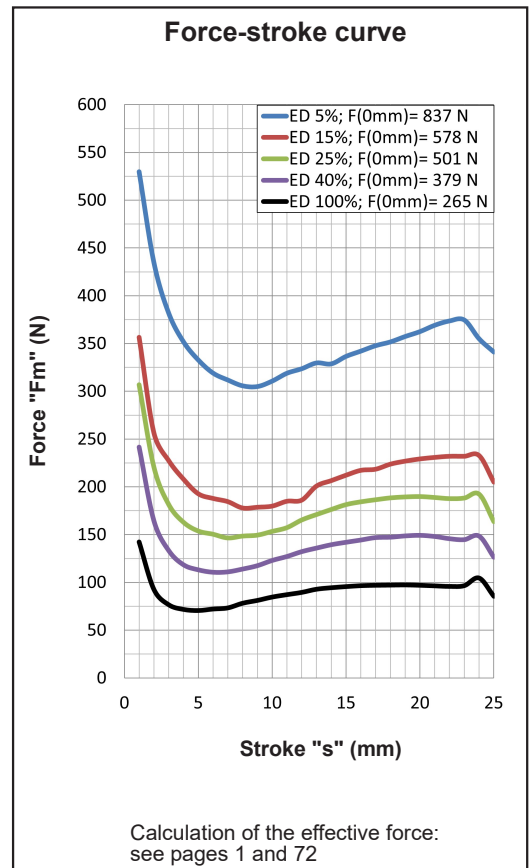
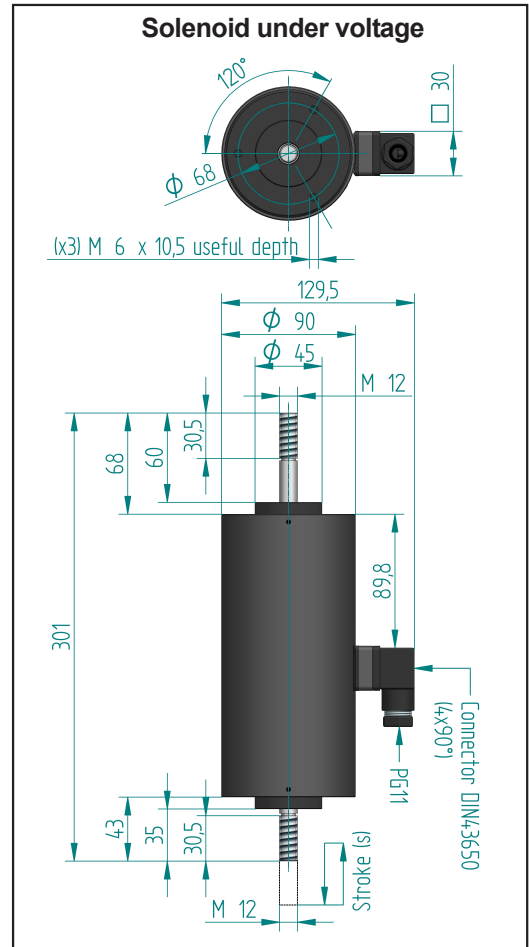

For fixation of the solenoid: see page 72