

● ECM 19/T TYPE

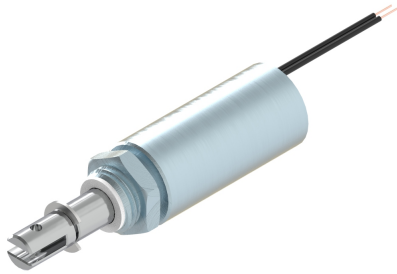

Protection rate: **IP30**
 Insulation class: **B (130°C)**
 Reference cycle: **2 minutes**
 Standard stroke (s): **10 mm**
 Temperature rise " ΔV_{31} ": **70°C**
 Working temperature: **-10 to 45°C**
 Work: **Pull**

Release spring NOT
incorporated in standard
product.

(ED) Duty-cycle ED(%)	100	40	25	15	5
(P20) Power at 20°C (W)	7	17	28	45	140
(Fm) Solenoid force (N) 1)	0.5	1.2	2	3.2	6.6
Max time under voltage(s)	Inf	48	30	18	6
Opening time (ms) 2)	44	40	38	37	34
Release time (ms) 3)	39	39	38	38	36
Plunger weight (Kg)	0.020				
Solenoid weight (Kg)	0.080				

1) Fm Solenoid force is given according to VDE0580 without deducting the spring force or the plunger weight if vertical mounting.

2) Time is given on these conditions: Coil supplied under nominal voltage ; Stabilized in it's working temperature ; Load 70% of the solenoid force ; Horizontal assembly ; Standard stroke initial position; 20°C ambient temperature.

3) Time is given on these conditions: without load on shaft ; Horizontal assembly ; Standard stroke initial position.

Duty-cycle ED%	Standard voltages								Under demand				
	VDC				VAC				VDC		VAC		
	6	12	24	48	100	125	205	110	230	Min	Max	Min	Max
100	o	o	o	o	o	o	x	x	x	3	125	x	x
40	o	o	o	o	o	o	o	x	x	3	230	x	x
25	o	o	o	o	o	o	o	x	x	5	250	x	x
15	o	o	o	o	o	o	o	x	x	5	250	x	x
5	x	o	o	o	o	o	o	x	x	9	250	x	x

Layout: o = Available ; x = Unavailable

- Voltage under demand:
They can be manufactured at voltages between the maximum and minimum voltage values shown in the chart.

- The duty cycles described in the chart are standard, they can be manufactured in any intermediate value.

- If any customization from the original is needed, please ask us.

- Earthing is recommended if the metallic parts are accessible.

Ordering code: ECM19/T --V ED---%

Voltage: 24Vdc; Duty cycle: ED100%
ECM19/T 24Vdc ED100%

Voltage: 12Vdc; Duty cycle: ED15%
ECM19/T 12Vdc ED15%

Solenoid under voltage (s=0mm position)

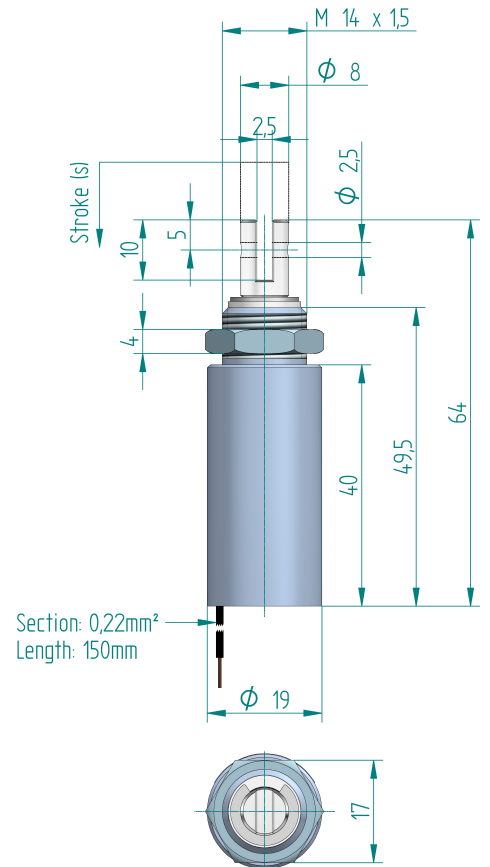

Force-stroke curve

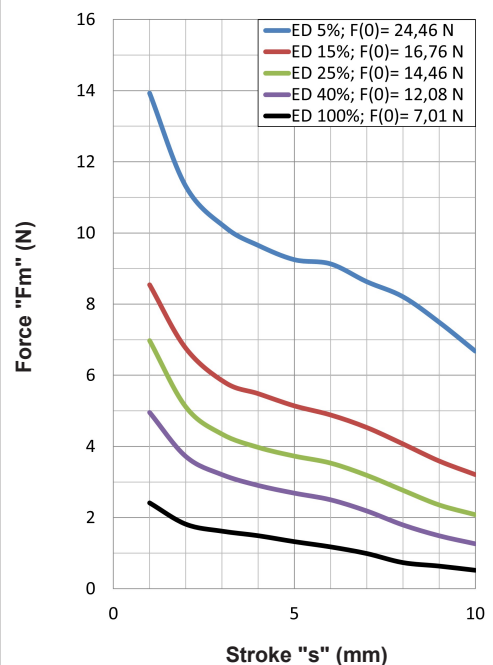

Calculation of the effective force:
see pages 1 and 59

For fixation and mounting positions: see page 59